

W. BREDE.

SHAPING ATTACHMENT FOR ENGINE LATHES.

No. 181,032.

Patented Aug. 15, 1876.

Fig: 1.

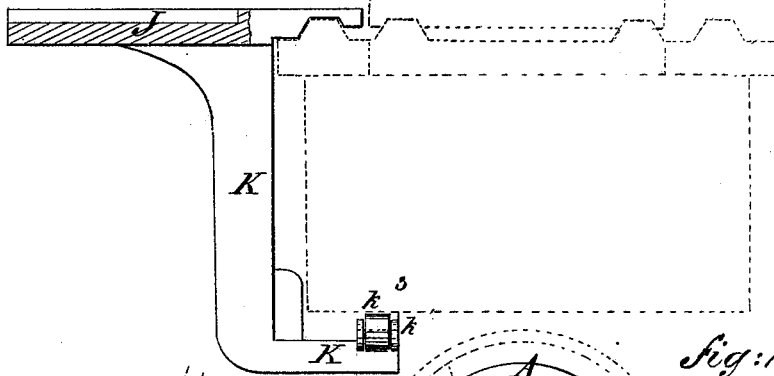
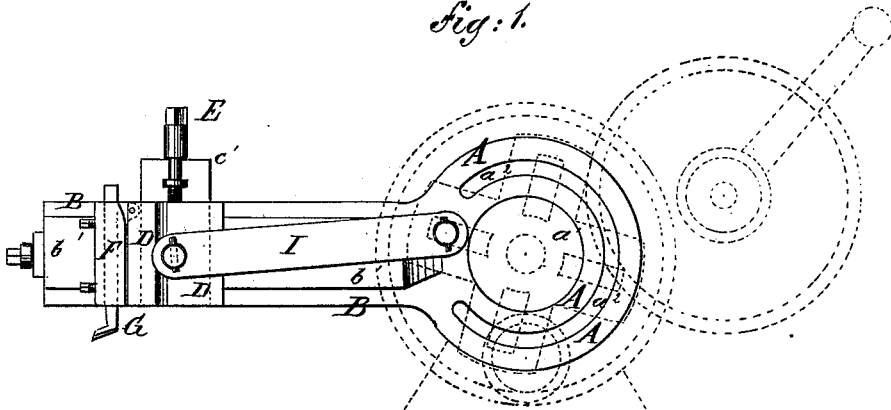
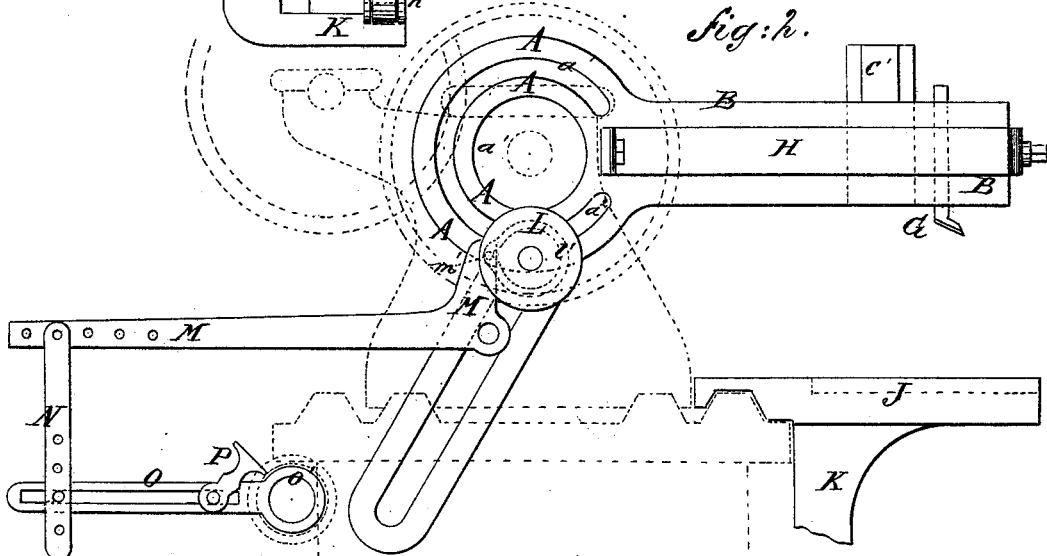

Fig: 2.



WITNESSES:

Chas. Nida
John Gottlieb

INVENTOR:

Wm. Brede

BY

Mumford

ATTORNEYS.

W. BREDE.

SHAPING ATTACHMENT FOR ENGINE LATHES.

No. 181,032.

Patented Aug. 15, 1876.

Fig. 3.

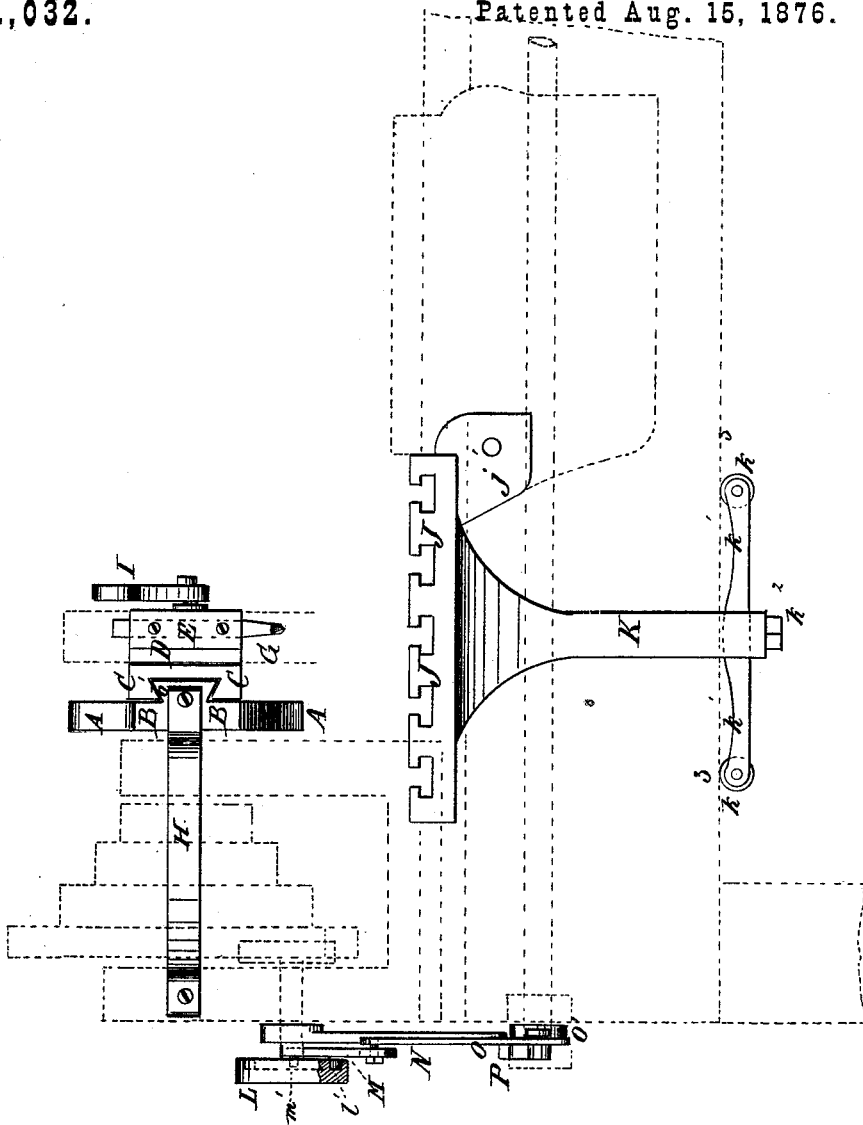

WITNESSES:

Chas. Nida
John Goetsch

INVENTOR:

Wm. Brede
 BY *M. M. M.*
 ATTORNEYS.

UNITED STATES PATENT OFFICE.

WILLIAM BREDE, OF LIHNE, ISLAND OF KANAI, HAWAIIAN ISLANDS.

IMPROVEMENT IN SHAPING ATTACHMENTS FOR ENGINE-LATHES.

Specification forming part of Letters Patent No. **181,032**, dated August 15, 1876; application filed July 31, 1876.

To all whom it may concern:

Be it known that I, WILLIAM BREDE, of Lihue, in the Island of Kanai, Hawaiian Islands, have invented a new and useful Improvement in Shaping Attachments for Engine-Lathes, of which the following is a specification:

Figure 1 is a side view of my improved attachment. Fig. 2 is a view of the reverse side of the same. Fig. 3 is a front view of the same.

Similar letters of reference indicate corresponding parts.

The object of this invention is to furnish an improved shaping attachment for lathes, which shall be so constructed as to do all the work required by an iron or brass worker, while saving the space that would be occupied by a shaping-machine, and at the same time being much less expensive.

The invention consists in the combination of the slotted plate, the arm provided with a dovetail tongue, the blocks, tool-holder, and swiveled screw, and the connecting-bar, with each other, to adapt them to be applied to the face-plate, spindle, and frame of a lathe; in the table provided with the lug, the bent arm, and the adjustable cross-bar, to adapt it to be applied to the lathe-bed, the carriage, and the frame of a lathe; and in the combination of the cam-wheel, the bent lever, the connecting-bar, the slotted bar provided with the collar, and the pawl, to adapt them for attachment to the friction-wheel and the feed-screw of a lathe, as hereinafter fully described.

A is a plate, having a hole, *a'*, through its center, for the passage of the lathe-spindle, and a segment of a ring-groove around its outer part, to receive the screws by which it is secured to the bracket or frame in which said lathe-spindle revolves. Upon the plate A is formed an arm, B, having a dovetail tongue, *b'*, upon one side, to receive the block C, which slides longitudinally upon it. Upon the outer side of the block C is formed a dovetail tongue, *c'*, upon which slides a block, D, as it is moved up and down by a screw, E, swiveled to the block C, and passing through a nut attached to the block D. The forward side of the block D is grooved to receive the tongue formed upon the rear side of the tool-holder F, to keep it from lateral movement.

The tool-holder F is pivoted at its upper end to the upper end of the block D, to allow the tool G to swing forward while being drawn back to make another cut.

For heavy work, the attachment may be strengthened by a brace-bar, H, the forward end of which is bolted to the forward end of the arm B, and its rear end is bolted to the bracket or bearing of the lathe.

I is the driving-pitman, the forward end of which is pivoted to the block D, that carries the tool-holder F, and its rear end is pivoted to the face-plate of the lathe, so that the cutter may be operated by the revolution of said face-plate. J is the table, to which the work is to be secured. The inner edge of the table J rests upon the lathe-bed, and upon said table is formed a lug, *j'*, to receive the bolt by which it is secured to the lathe-carriage, so that the work attached to said table may be fed to the cutter by the movement of the lathe-carriage. Upon the under side of the table J is formed an arm, K, the lower end of which is bent inward at right angles, and has a cross-bar, *k¹*, secured to it adjustably by a set-screw, *k²*, to rest against the lower side of a bar of the lathe-frame, to hold the table J steady as it moves forward. To the ends of the cross-bar *k¹* are pivoted rollers *k³*, to diminish the friction between said bar and the frame of the lathe. To the shaft of the friction-pulley that drives the feed-screw of the lathe is attached a wheel, L, in the side of which is formed a cam-groove, *l'*, to receive the pin *m'*, attached to the short arm of the lever M. The lever M is pivoted at its angle to the frame-work of the lathe, and in its long arm are formed a number of holes, to receive the pin or bolt by which the upper end of the connecting-bar N is pivoted to said arm. The lower part of the connecting-bar N has a number of holes formed through it, to receive the pin or bolt by which it is pivoted to the slotted bar O. Upon the other end of the bar O is formed a collar, *o'*, to receive and ride upon the feed-screw of the lathe. To the bar O is pivoted a pawl, P, to engage with the ratchet or gear wheel attached to the feed-screw of the lathe, and through which motion is given to said feed-screw.

By this construction the work is fed forward after each stroke of the cutter G, the amount

of feed each time being regulated by adjusting the pivoting-points of the lever M and bars N O.

Having thus described my invention, I claim as new and desire to secure by Letters Patent—

1. The combination of the slotted plate A, the arm B, provided with a dovetail tongue, *b'*, the blocks C D, tool-holder F, and swiveled screw E, and the connecting-bar I, with each other, to adapt them to be applied to the face-plate, spindle, and frame of a lathe, substantially as herein shown and described.

2. The table J, provided with the lug *j'*, the bent arm K, and the adjustable cross-bar *k'*,

to adapt it to be applied to the lathe-bed, the carriage, and the frame of a lathe, substantially as herein shown and described.

3. The combination of the cam-wheel L, the bent lever M, the connecting-bar N, the slotted bar O, provided with the collar *o'*, and the pawl P, with each other, to adapt them for attachment to the friction-wheel and the feed-screw of a lathe, substantially as herein shown and described.

WILLIAM BREDE.

Witnesses:

J. B. CASTLE,
JAMES RICHARDSON.